

Erratum

The 'Dibble' – A digital mode interface box, with an introduction to PSK31

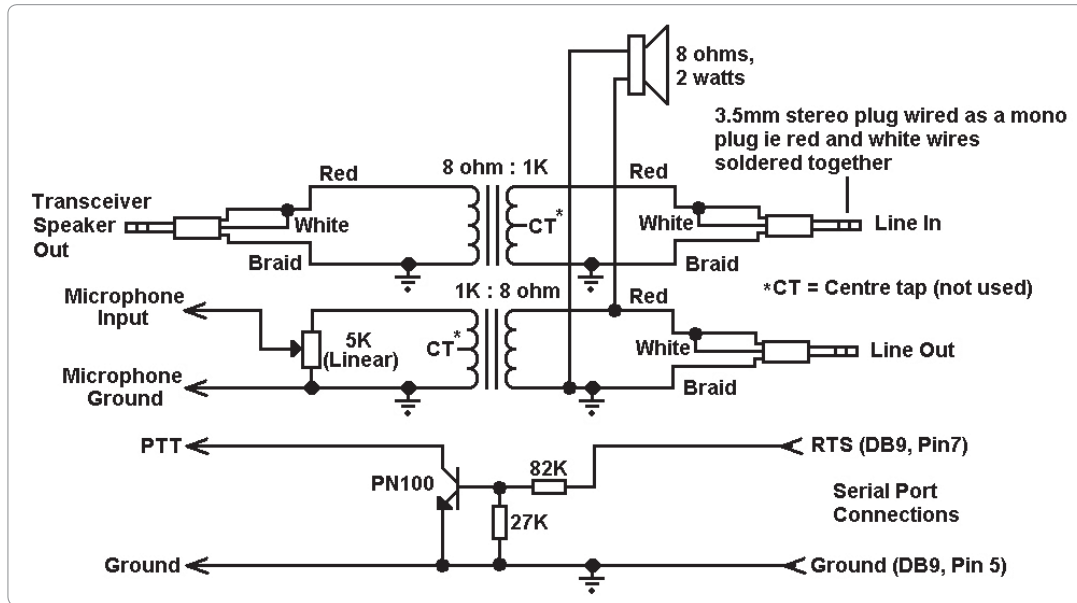

The author of this article, published in the January/February 2012 issue of AR, Ross Fraser VK2WN advises that the original Figure 4 had a couple of mistakes and that the replacement Figure 4 has corrected those errors – being the placement of a speaker in the line out circuit and the addition of an earth in the PTT section.

Figure 4: Schematic diagram of the 'Dibble'.



www.ttssystems.com.au
 Phone: 03 5977 4808 Email: info@ttssystems.com.au
 Your Australian reseller for:

YouKits

New Products coming soon

AVAILABLE NOW

Hard Drawn Copper Wire, Insulators, Dipole Centres
 Open Wire Transmission Line, Spreaders, Kevlar Guy Line
 Spiderbeam Fibreglass Poles, Baluns and Switches



Meanwell power supplies
 Diamond products
 Daiwa products
 Technical books
 Amidon products
 Custom cables made to order

As always, you can get a free catalogue - just call!